

Methods For Implementing the Microelectronic Operation of The Automatic Push-Button Circuit and The Arrow Control Circuit and The Control Block Npm-69-M

Ubaydullayev Saidazim Qahramon o'g'li

Assistant of the Department of Automation and Telemechanics, Tashkent State Transport University

Annatation: The article discusses the application and localization of electromagnetic relays, which are one of the most important elements in railway transport control systems. To solve these problems, the issues of modeling processes and finding a technical solution using microelectronic devices, improving efficiency and reliability are considered. To solve these problems, methods and technologies of microelectronic devices have been developed.

Keywords: Railway transport, electromagnetic relay, modelling, automatic button chain, stretch control and control chain compliance scheme, functional block.

Introduction

Activation of the process of using microprocessors is gaining momentum on the railways of the Commonwealth of Independent States (CIS) countries and the Republic of Uzbekistan. The output of energy-saving electromechanical relays is being reduced, which account for 80% of the existing installations of Uzbekistan Temir Yullari Joint Stock Company (JSC) "UTY" in railway automation and telemechanics. To solve the transition to microelectronics, research has been conducted on this problem for several years. For example, JSC "UTY" is introducing a new microprocessor-based electric centralization system on the railways, a new station and stations located on sections intended for the movement of high-speed passenger trains. Block route-relay centralization (BRRC) schemes for stations with the desired number of arrows are compiled according to the geographical principle according to the topology of the single-threaded plan of the station, by mutual connection of the aggregate and executive blocks. The application of this principle in the preparation of electrical circuits greatly simplifies the maintenance of systems, troubleshooting. Microprocessor systems, despite the presence of powerful auxiliary functions, do not possess this principle, as a result of which maintenance and troubleshooting becomes much more complicated. This is confirmed by the experience of using such systems. During the warranty service, the device manufacturer is engaged in troubleshooting, replacing faulty modules and blocks, and software problems. However, after the expiration of the warranty period, these issues remain on the shoulders of the railway as economic problems. In microprocessor systems, making changes to the station configuration is a specific problem that requires reprogramming the CPU. In a microprocessor-based electrical centralization system, software makes up 80% of its volume. Therefore, any change in the configuration of a station equipped with microprocessor-based electrical centralization, from an economic point of view, is equivalent to the construction of a new system.

Material And Methods

The purpose of this article is to solve innovative problems in the use of contactless devices, which will ensure an increase in the safety of transportation by increasing the reliability, technical condition of devices, control. To achieve this goal, digital information processing and modeling methods based on the theory of Petri nets were used.

Results And Discussion

In the technological processes of large stations, more serious requirements are imposed on centralization devices than on small stations, because due to the large number of arrows (15 or more), the time for preparing routes is significantly increased with separate control of arrows and signals. For this purpose, a route preparation system has been developed in automatic mode, with pressing the start and end buttons. This system is called block route-relay centralization (BRRC) and is widely used at stations of precinct, sorting and intermediate purposes with more than 30 arrows and a large volume of train shunting work.

About 70% of all BRRC equipment is placed in functional block manufactured at factories in the form of standard designs. In addition, the block development of functional units significantly reduces the design and construction time of the station's electrical centralization systems, as well as simplifies the maintenance process.

The BRRC contained two groups of functional blocks. The first of them, called the dial group, records the actions (button presses) of the station attendant on the control panel and, accordingly, transmits the corresponding commands to the second group, called the executive group. It is made on the basis of a relay code (KDR) that does not belong to the category of reliability of the first class, since the dial group does not control the safety conditions

The executive team ensured that the trains had control over the safety of movement, and therefore were carried out on the basis of NM-type relays in terms of first-class reliability. The dial is placed according to the plan of the station in accordance with the task performed by the group blocks and interconnects them according to the four main chains.

The first is a chain of button relays that records the pressing of buttons on the control panel, as well as schemes of Re-activation, auxiliary finishing and auxiliary train relays are included.

The second is an automatic push rails (AKN) chain consisting of two or more elementary routes, which allows the dialing group to automatically activate push rails on the signal blocks when setting up trains or receiving routes.

The third the arrow control relay circuit (PUMA) serves to give the command to move the arrows to the appropriate position along the route of the prepared route.

The fourth the matching scheme checks whether the position of the arrows corresponds to the specified route.

This article will review research on the implementation of the NPM-69 block using microprocessor devices. The functional function of this unit is to monitor and monitor the condition of trains and shunting traffic lights, as well as shunting traffic lights on the section of track located at the entrance to the station. Consider the circuit diagram of the automatic push-button relays (AKN) of the NPM-69 unit and the relay circuit of the switch control (PU, MU) (Figure.1). The second and third circuits of the BMRM dial group are the circuit of automatic push-button relays (AKN) and the circuit of switch control relays (PU, MU), with the help of a relay with an automatic button (AKN), the route is configured using a remote manipulator by pressing two buttons-the start and end. The relay of the switch controller (PU, MU) controls the arrows and checks their real position after switching from one state to another.

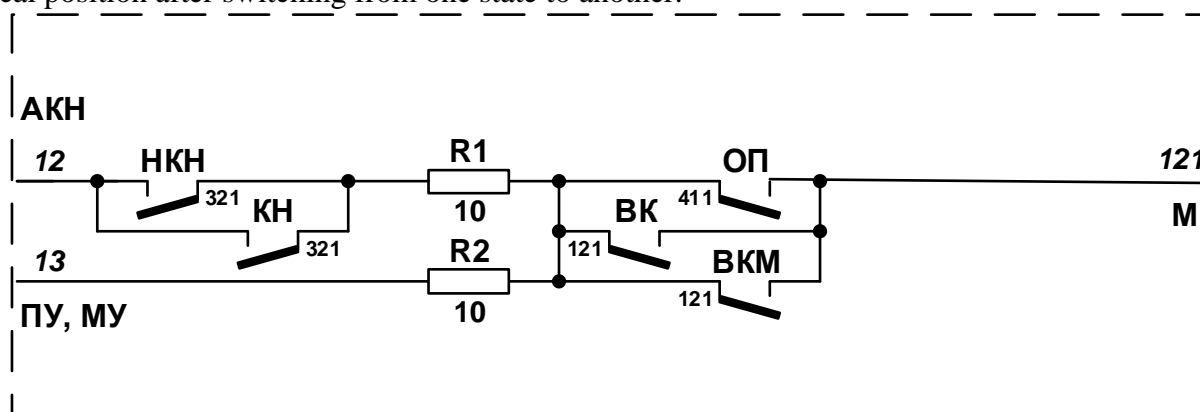

Figure.1 Circuit diagram of automatic push-button relays (ACN) and switch control relay circuits (PU, MU) in the NPM-69 block.

As can be seen from Figure 1, the relay with automatic switching (AKN) through the leg 1.2 for the munba train route coming from the circuit passes through the NKN contacts and exits to M through the leg 1.21 via the OP relay contacts against duplication. If the route is intended for a 1.2 m maneuver, the one entering through the footboard passes through the KN relay contacts and exits to the 1.21 m pole via the relay contacts against repetition. The relay controlling the arrow issues commands to control the position of the arrow. In this case, the sample that entered the circuit through the leg 1.3 goes to the pole m through the leg 1.21 through the contacts of the relay VKM.

The NPM-69 unit is built on the basis of KDR type electromagnetic relays, which means that when checking the operation of its current-carrying units, when replacing them with microprocessor units, it becomes necessary to develop new units capable of preserving the existing functionality of all electrical circuits.

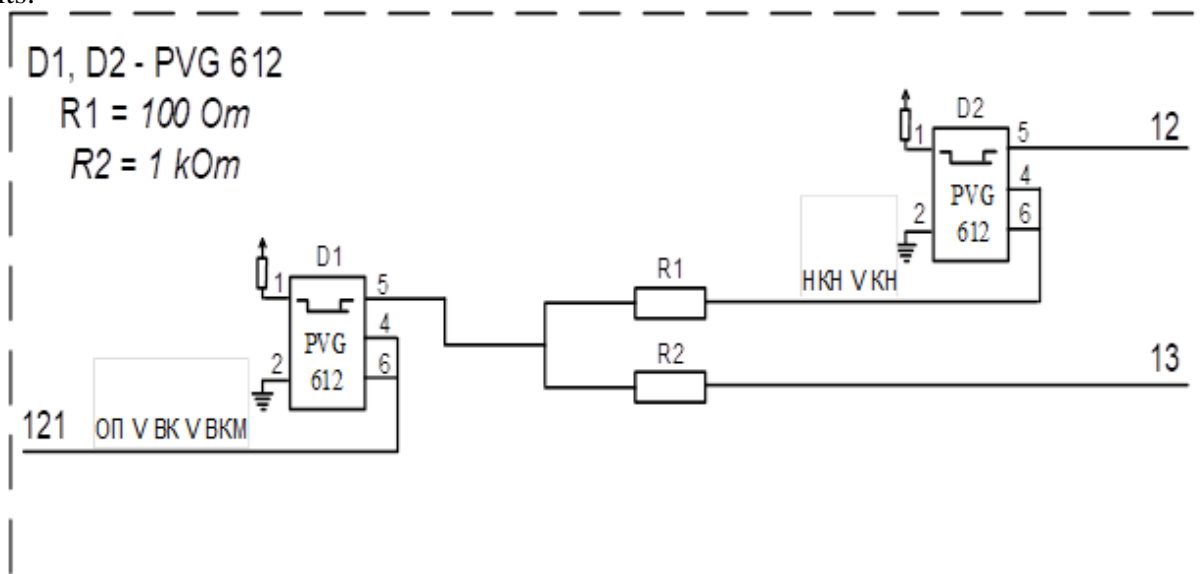

Figure.1 The NPM-69 block. uses an electrical circuit for connecting power to the circuit of automatic push-button relays (ACN) and the relay circuit of the switch control (PU, MU) of the PVG-612 optorele block..

In Figure 2, the 1.2 input of the source D2 through the 5 input of the first state (the current of the NKN relay) of the element 1 (the current of the OP relay) of the 5 input of the Manba D1 through the first state of the first state (the current of the NKN relay) of the first state of the.

In the second case, the 1.2 input of the source D2 through 5 klemma moving according to the state of the second case (kn relay current) the 5 input of the element D1 (op relay current) in the second case the 1.2 input of the source D2 and the 2px signal in the 1.21 klemma cause, the appearance of this

In the third case, the source through 1.3 klemma causes the signal 1px in 1.2 klemma and 1.21 klemma, moving according to the state of the third state (VKM relay current) of the 5 input of the source D3, the appearance of this signal means that the release of the Px3 (VKM strelka) in the microprocessor software has been launch

Acknowledgement

The use of the achievements of modern system engineering makes it possible to provide more efficient and safe control of the transport process in the conditions of increasing need for rejection of electromagnetic relays. Solving innovative problems in the use of contactless devices in railway transport control systems, will provide an increase in the safety of transportation by increasing the reliability, technical condition of devices, control. To achieve this goal, methods of digital information processing and modeling based on the theory of Petri nets were used. Based on the results of the study of the operation model of push-button relays of the beginning and end of maneuvering routes, algorithms are obtained and software for the microcontroller, a schematic diagram of switching on the push-button relay of the unit has been developed НПИМ-69-М, made on a contactless basis.

References

1. Аметова Э.К., Азизов А.Р. Теория сетей Петри при разработке и исследовании математической модели блока НСО. ФарПИ ИТЖ. 2019, №5 с.93-98.
2. Azizov A.R, Ametova E.K. NSS Mikroelektron blokini yaratish. ToshTTYMI Ahboroti. 2019 №2. 155-160 b.

3. Аметова Э.К., Азизов А.Р. Исследование модели цепи кнопочных реле микроэлектронного блока НСС. Мухаммад ал-Хоразмий авлодлари. Мухаммад ал-Хоразмий номидаги Тошкент ахборот технологиялари университети 2019, №3(9) 75-77 б.
4. N. Arifov, A. Sadikov, S. Ubaydullayev. Intelligent signal detectors with random moment of appearance in rail lines monitoring systems. // E3S Web of Conferences 264, 05039 (2021). CONMECHYDRO – 2021.
5. Ubaydullayev S.K Methods of microelectronic operation of the NPM-69-M block compliance scheme. Galaxy international interdisciplinary research journal (GIIRJ) Vol. 9 №12 27 dec 2021 page 1200-1204.
6. Аметова Э.К., Азизов А.Р. Исследование модели цепи кнопочных реле микроэлектронного блока НСС. Мухаммад ал-Хоразмий авлодлари. Мухаммад ал-Хоразмий номидаги Тошкент ахборот технологиялари университети 2019, №3(9) 75-77 б.
7. Sadikov A.N. Analysis of promising systems for monitoring the state of rail lines for the railways of the Republic of Uzbekistan. European Scholar Journal (ESJ). Vol. 2 No. 8, August 2021.
8. Goce L. Arsov The 40-th Anniversary of the Simulation Program with Integrated Circuit Emphasis – SPISE, IX Symposium Industrial Electronics INDEL 2012, Banja Luka / L. Gose. – November 1–3. –2012. – Pp. 6–21.
9. Дж. Питерсон. Теория сетей Петри и моделирование систем: пер. с англ. / – М.: Мир, 1984. – 264 с.
10. Бестемьянов П.Ф. Методы повышения безопасности микропроцессорных систем интервального регулирования движения поездов. Докторская диссертация, Москва, 2001, 324с.