

# Method And Results For Developing A Device For Electro-technological Treatment Of Apple Trees In Intensive Orchards

Ilhom Kholmirezayev, Dostonbek Sheraliev, Sobir Eshmurodov, Jumanazar Qodirov, Jahongir Esanov, Abbosjon Kholiyorov.

Termez University of Engineering and Agrotechnology

**Abstract:** This study presents the development and evaluation of an electrotechnological device for controlling aphids on apple trees in intensive orchards using UV-C radiation (253.7 nm). The research is based on an analysis of plant diseases, pest control methods, and electrophysical approaches. Field experiments showed that treatment efficiency depends on distance and exposure time. The highest efficacy (98.1%) was achieved at a 0.3 m distance with a double 20-minute treatment, while increasing the distance reduced effectiveness. Economic analysis demonstrated significant cost savings, with the UV-C method reducing expenses by 40,734,000 UZS over three years compared to chemical treatment. The device is simple, portable, energy-efficient, and environmentally safe, making it an effective alternative to chemical pest control.

**Keywords:** Ultraviolet radiation (UV-C), electrotechnology, aphid control, intensive orchards, apple trees, pest management, biological and economic efficiency, environmentally friendly technology

**Introduction:** Sustainable agriculture requires effective and environmentally safe pest control methods. Aphids are among the most harmful pests affecting apple trees in intensive orchards due to favorable conditions for rapid spread.

Traditional chemical methods, although effective, cause environmental pollution, harm human health, and lead to pest resistance. Therefore, alternative approaches are needed. Electrophysical methods, particularly UV-C radiation (253.7 nm), offer a promising solution due to their strong biological impact without chemical use.

The aim of this study is to develop and justify an electrotechnological device for controlling aphids using UV-C radiation and to evaluate its biological and economic effectiveness under practical conditions.

**Development of an Electrotechnological Device for Treating Apple Trees with Ultraviolet Radiation.** Based on a study of the current state of the issue, namely: the impact of plant diseases on crop yields, methods for controlling plant diseases, electrophysical methods for controlling plant diseases and pests, an analysis of agrotechnologies for protecting agricultural crop seeds and plants against diseases and pests, and theoretical research on treating aphid-infested apple trees with ultraviolet radiation, a device was developed for treating aphids on apple trees in intensive orchards with ultraviolet rays based on an electrotechnological method. Figure 1 illustrates the schematic diagram of a device, based on an electrotechnological method, for treating apple trees in intensive orchards against aphid pests with ultraviolet rays.

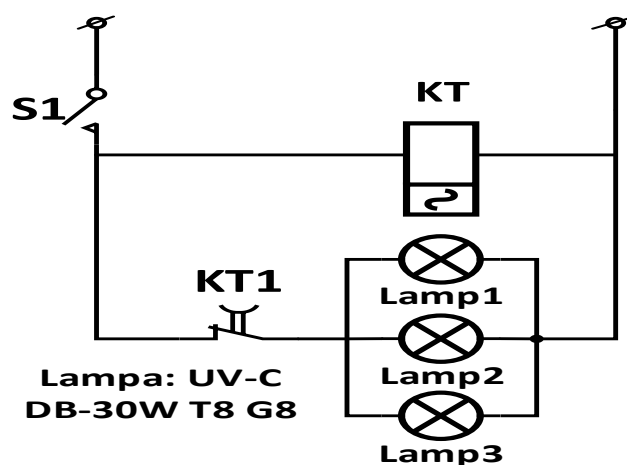

a)

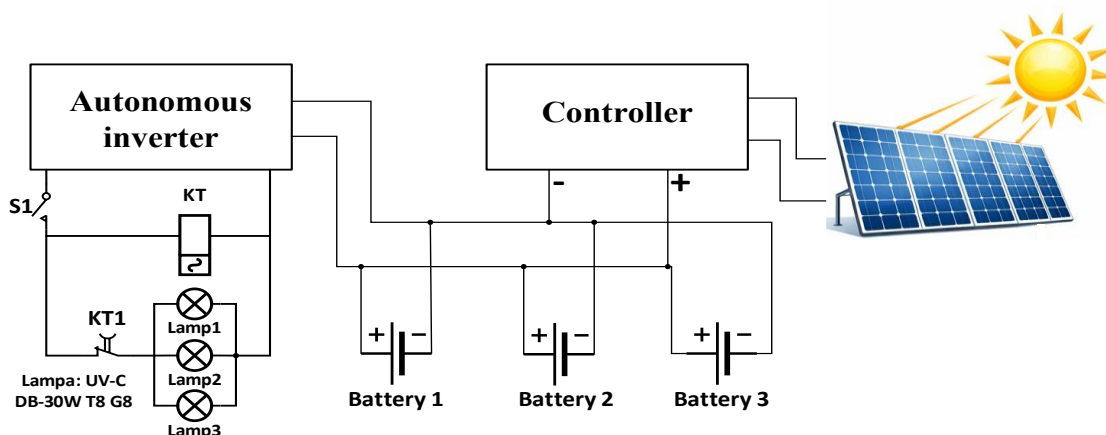

b)

a) Connection diagram to a 220V source; b) Connection diagram to a solar panel

**Figure 1. Network connection diagram of the device for treating apple trees with ultraviolet rays.**

The network connection diagram of the device consists of the following components. The network connection circuit includes an S1 connector, a KT magnetic starter, and three UV-C DB-30W T8 GB ultraviolet lamps. The circuit connected to the solar panel includes a controller, 3 storage batteries, a standalone inverter, a connector (S1), a magnetic starter, and 3 UV-C DB-30W T8 GB ultraviolet lamps. The device consists of a base (1), a connector S1 (2), a magnetic starter KT (3), and 3 UV-C DB-30W T8 GB ultraviolet lamps (4). Its operating principle is as follows: It is brought to an intensive orchard and adjusted according to the height of the apple tree. Then, the distance between the apple tree and the device is set, and it is connected to the mains or to solar panels via the inverter and storage batteries. Figure 2 depicts a general view of the device for treating apple trees with ultraviolet rays in intensive orchards.

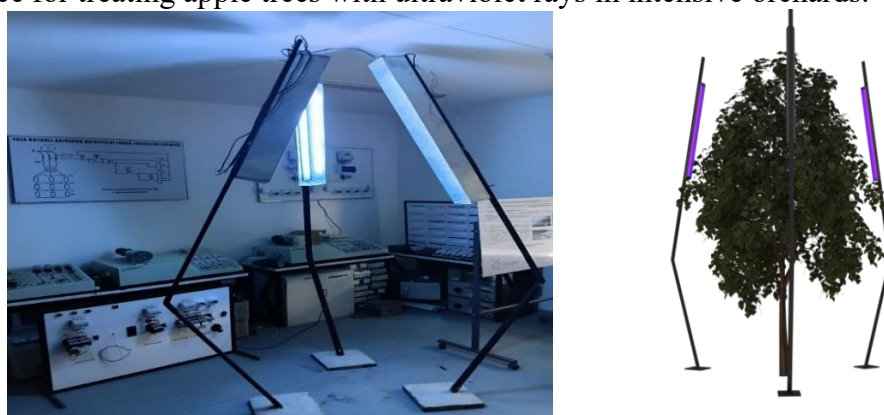

**Figure 2. General view of the device for treating apple trees with ultraviolet rays.**

The device is designed for apple trees in intensive orchards and has a structurally simple design. Based on the results obtained from field trials, the treatment is administered with the lamps' exposure time set to 18–20 minutes and the distance set to 0.3–0.45 meters. Chapter iv device test results and determination of technical-economic effectiveness. Brief Technical Specifications of the Device. A prototype of a device based on an electrotechnological method was developed based on an analysis of scientific research on the electrotechnological treatment of agricultural crop seeds and plants, a theoretical study of ultraviolet light treatment for apple trees infested with aphid pests, and the results of experimental research conducted to combat aphid pests on apple trees.

Table 1 provides a brief technical specification for the developed ultraviolet light device for controlling aphid pests on apple trees in intensive orchards.

Table 1

**Technical Specifications of the Device**

No	Parameter	Unit of Measurement	Value
1	Type		Portable
2	Number of lamps	pcs	3
3	Lamp length	mm	600
4	Wavelength of light	nm	253.7
5	Mains voltage	V	220
6	Power source		Mains or solar panels
7	Power consumption	W	90
8	Effective distance	m	0.3
9	Exposure time	min	20
10	Overall dimensions-height	mm	300
11	Mass	kg	15

The device is designed to be portable for controlling aphid pests on apple trees in intensive orchards. It consists of 3 lamps, each 600 mm in length. The wavelength of the ultraviolet light is 253.7 nm, and the lamps are powered by a solar panel or an accumulator battery. In this case, the operating voltage is 12 V. The power of each UV-C lamp is 30 W, the distance from the radiation source to the apple tree is 0.3 m, and the exposure time is 20 minutes. The overall dimensions of the device are a height of 300 mm and a mass of 15 kg.

**Results of Field and Farm Trials of the Device.** Field and farm trials of the device were conducted in the intensive orchards of the “ANGOR SHIRIN” and “G‘ULOMOV BAXRIDDIN” former xo‘jaliklari farms in the Bandixon district of Surxondaryo region, as well as at the experimental plot of the Scientific Research Institute of Plant Quarantine and Protection.

Figure 3 depicts the process of controlling aphid pests on apple trees in intensive orchards using the proposed device.

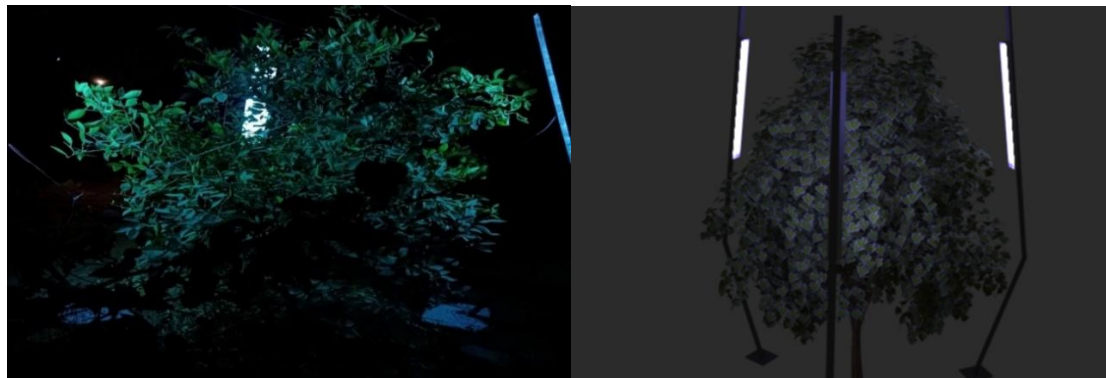

**Figure 3. The process of controlling aphid pests on apple trees using the proposed device**

Table 2 presents the results of the device's field and farm trials for controlling aphid pests on apple trees in intensive orchards.

Table 2

**Effect on insects when the distance between the device and the apple tree is 0.3 m**

Treatment Duration (minutes)	Number of insects (pcs)	Number of surviving insects after 1st treatment (pcs)			Efficacy %	Number of insects (pcs)	Number of surviving insects after 2nd treatment (pcs)			Efficacy %
		1	3	5			6	8	10	
0	167	57	37	4	<b>43.8</b>	135	26	1	9	<b>71.2</b>
10	165	154	134	84	<b>49.1</b>	132	114	76	32	<b>75.8</b>

20	186	69	32	7	<b>69.4</b>	105	5	7	2	<b>98.1</b>
Control	162					130				

Table 2 presents the results of field and farm trials of a developed electrotechnological device designed to combat aphid pests on apple trees in intensive orchards. During the experiments, the distance between the device and the tree was set at 0.3 m, and the treatment time was varied between 10, 15, and 20 minutes. After each treatment, the number of surviving insects and the biological efficacy percentage were determined. An analysis of the table shows that the decrease in the insect population after the first treatment was directly dependent on the treatment duration. Specifically, the efficacy was 43.8% with a 10-minute treatment, increasing to 49.1% at 15 minutes, and reaching 69.4% with a 20-minute treatment. These results indicate that as the radiation energy dose increases, the physiological activity of the aphids is suppressed, and their mortality rate rises.

The results after the second treatment clearly demonstrate the device's cumulative effect. While the efficiency increased to 71.2% with a 10-minute treatment and to 75.8% with a 15-minute treatment, a second 20-minute treatment resulted in an efficiency of 98.1%. In the control group, however, no significant decrease in the aphid population was observed. This confirms that the results recorded in the experimental groups are not due to random factors but are directly related to the radiation effect of the device. In conclusion, it was determined that a double 20-minute treatment regimen at a distance of 0.3 m provides the highest biological efficacy against aphids. The results obtained allow the developed device to be recommended as an effective, environmentally friendly, and chemical-free technology for pest control in intensive orchards.

Table 3 presents the results of the device's field and farm trials for controlling aphid pests on apple trees in intensive orchards.

Table 3

**The effect on insects when the distance between the device and the apple tree is 0.6 m**

Treatment Duration (minutes)	Number of insects (pcs)	Number of surviving insects after the 1st treatment (pcs)			Efficacy %	Number of insects (pcs)	Number of surviving insects after the 2nd treatment (pcs)			Efficacy %
		0	1	3			5	0	6	
10	183	173	157	112	<b>38.8</b>	152	132	00	9	<b>61.2</b>
15	167	157	138	90	<b>46.2</b>	127	112	79	40	<b>68.6</b>
20	182	166	135	63	<b>65.4</b>	106	91	57	15	<b>85.9</b>
Control	162					108				

Table 3 shows the results of the device's effect on aphids when the distance to the apple tree was 0.6 m. The experiments were conducted using treatment times of 10, 15, and 20 minutes. According to the results of the first treatment, efficiency increased from 38.8% to 65.4% as the treatment time was extended. After the second treatment, the efficiency was 61.2%, 68.6%, and 85.9%, respectively. This indicates that the device's effect is enhanced with repeated application.

No significant change was observed in the control group. In general, although the device's effectiveness at a distance of 0.6 m was lower than at 0.3 m, it was determined that sufficient biological efficacy could be achieved by increasing the treatment time.

Table 4 presents the results of the device's field and farm trials for controlling aphid pests on apple trees in intensive orchards.

Table 4.4

**The effect on insects at a distance of 0.9 m between the device and the apple tree**

Treatment time (minutes)	Number of insects (count)	Number of surviving insects after the 1st treatment (count)			Efficacy %	Number of insects (count)	Number of surviving insects after the 2nd treatment (count)			Efficacy %
		0	1	3			5	0	6	
10	183	178	164	115	37.2	162	146	123	85	47.6
15	172	162	144	90	47.7	138	121	89	49	64.5
20	182	168	139	76	58.3	122	102	68	24	80.4
Control	162					108				

Table 4 presents the results of the device's effect on aphids when the distance to the apple tree was 0.9 m. The experiments were conducted using treatment durations of 10, 15, and 20 minutes. The results of the first treatment showed that as the duration increased, effectiveness rose from 38.8% to 65.4%. After the second treatment, the effectiveness was 47.6%, 64.5%, and 80.4%, respectively. This indicates that the impact of the device intensifies with consecutive applications. No significant changes were observed in the control group. Overall, the results showed that the device's effectiveness at a distance of 0.9 m was lower than at 0.6 m. Thus, it was observed that effectiveness decreases as the distance increases, even when the exposure time is extended.

**Determining the technical-economic effectiveness of the electrotechnological treatment device against aphids on apple trees** It is crucial to evaluate the effectiveness of methods used to control aphids, which are pests of agricultural crops, not only from a biological or ecological perspective but also from an economic one.

This section presents a comparative economic analysis based on elements such as the costs of pesticides (chemical preparations), labor, and equipment for chemical treatment, as well as the operational expenses for the developed UV-C device, including electricity, labor, and depreciation. This analysis aims to determine the annual costs of both methods, calculate the total profit and savings coefficient, and substantiate their efficiency using precise mathematical formulas. The results will serve to demonstrate the advantages of modern, environmentally friendly technologies in plant protection, not only scientifically but also practically. The wholesale prices of chemical pesticides for orchard plants and their consumption rate per hectare of land have been calculated below. These calculations utilized methodological guides for determining the economic efficiency of implementing new technologies, inventions, and rationalization proposals in production, along with data from regulatory guidelines [134, p. 19]. To evaluate the economic efficiency of the chemical method widely used for aphid control, the costs of treating a 0.7-hectare area using this technology were analyzed based on data from the district's chief agronomist and the farm's manager. According to the data, 1.05 liters of chemical pesticide are required for each application. In line with market prices, the average price of 1 liter of the pesticide is 900,000 soum. Therefore, the cost for 1.05 liters is calculated as follows:

$$C_{\text{pesticide}} = 1.05 \times 900,000 = 945,000 \text{ soum.}$$

In addition, the labor cost for each application was set at 400,000 soum. Chemical treatment is carried out during two seasons per year. Considering that spraying is conducted an average of up to 6 times per season, the total number of annual applications is 12:

$$N_{\text{annual}} = 2 \times 6 = 12 \text{ times}$$

Based on this, the total annual pesticide and labor costs are as follows:

$$C_{\text{chemical}} = (C_{\text{pesticide}} + C_{\text{labor}}) \times N_{\text{annual}} = (945,000 + 400,000) \times 12 = 16,140,000 \text{ soum}$$

Furthermore, the cost of the sprayer required for the treatment is 1,500,000 soum, and this equipment has a service life of at least three years. Therefore, its annual depreciation cost is

$$C_{\text{uskuna}} = \frac{1500000}{3} = 500,000 \text{ soum.}$$

As a result, the total annual cost of the chemical-based treatment is determined as follows:

$$\Sigma = 16140000 + 500000 = 16640000 \text{ so'm} \cdot C_{\text{chemical}}$$

UV-C light treatment technology is a modern, environmentally friendly, energy-efficient, and technologically simple method for controlling harmful aphid pests. The following technical and economic parameters were determined for applying this treatment technology on 0.7 hectares of intensive orchards at the “ANGOR SHIRIN” va “G‘ULOMOV BAXRIDDIN” fermer xo‘jaliklari horticultural farms in the Bandixon district of the Surxondaryo region. In the conditions of Uzbekistan, there are 750-800 apple trees per hectare of an intensive orchard. Therefore, the treatment amount is determined on a per-tree basis. For calculation purposes, it was assumed that there are an average of 780 trees per hectare in an intensive orchard. Taking this into account,  $780 \cdot 0.7 = 546$ , meaning there are 546 apple trees in an area of 0.7 ha.

The total cost of the UV-C lamp-based treatment device was calculated based on its components. The device consists of three 30W UV-C lamps, a time relay, a magnetic starter, as well as other necessary elements such as cables, a metal frame, and electrical connections. The total cost of the device is 780,000 UZS.

Table 2 provides information on the prices of the UV-C device components.

Table 2.

**Information on the prices of the UV-C device components**

Component Name	Quantity (pcs)	Price (UZS)	Total (UZS)
UV-C Lamp (30W)	3	170,000	510,000
Time Relay	1	65,000	65,000
Magnetic Starter	1	55,000	55,000
Additional Equipment (metal frame, cable, etc.)	–	150,000	150,000
Total:			780,000

Eight devices are required to treat the apple trees in a 0.7-hectare area. Based on this, the following calculations must be performed to determine the total initial investment cost for the 0.7-hectare plot. Considering that the results of the conducted experiments show the main parameters are dependent on power, distance, and time, the studies were tested at three time intervals: 10, 15, and 20 minutes, with the optimal treatment time found to be 18–20 minutes. Therefore, one device can treat three trees per hour. Taking the above into account, the calculations for 8 devices are as follows. Assuming one device operates for 8 hours a day, it can treat 24 trees. Now, considering that we need 8 such devices for a 0.7-hectare area, we get the following:

$$8 \text{ (devices)} \cdot 3 \text{ (days)} \cdot 24 \text{ (number of trees)} = 576.$$

Accordingly, the total initial investment cost for 0.7 hectares is

$$780,000 \cdot 8 = 6,240,000 \text{ som}.$$

With the device's service life taken as 5 years, the annual depreciation expense was calculated as follows:

$$\frac{6240000 \cdot 0,125}{5} = 156000 \text{ so'm}.$$

This value represents the capital expenditure accounted for annually through depreciation and substantiates the long-term economic benefit of the device.

$$\frac{546_{\text{daraxt}}}{24_{\text{daraxt/qurilma}}} = 22,75 \text{ qurilma}.$$

$$\frac{22,75}{8} \text{ If 8 devices are used} = 2.84 \text{ days}.$$

Therefore, it takes 2.8 days to fully treat a 0.7-hectare intensive orchard with 8 devices. Considering that treatments are applied twice per season, the total time required is  $2 \cdot 2.8 = 5.6$  days.

$$\text{Electricity consumption for 1 device: } 90 \text{ W} \cdot 8 \text{ hours} = 720 \text{ Wh} = 0.72 \text{ kWh}$$

For 8 devices:  $0.72 \cdot 8 = 5.76$  kWh  
Seasonal (5.6 days):  $5.76 \text{ kWh} \cdot 5.6 = 32.25$  kWh  
The price of electricity is 1,000 soums.  
 $32.25 \cdot 1,000 = 32,250$  soums.

Formula for determining economic efficiency

$$\frac{C_{\text{kimyo}} - C_{\text{UV-C}}}{C_{\text{kimyo}}} E = 100, \%$$

—where E is the economic efficiency of the UV-C method, in percent;

$C_{\text{kimyo}}$  — annual cost of the chemical method, in soums;

$C_{\text{UV-C}}$  — annual cost of the UV-C method, in soums.

Costs for electrotechnological treatment:

1. In the first year, the total cost of 8 devices is 6,240,000 soums, services for 4 treatments per year cost  $300,000 \cdot 4 = 1,200,000$  soums, and electricity costs  $64.5 \text{ kWh} \cdot 1,000 = 64,500$  soums.

$6,240,000 + 1,200,000 + 64,500 = 7,504,000$  soums

2. Second year:  $1,300,000 + 72,000 = 1,372,000$  soums

3. Third year:  $1,350,000 + 80,000 = 1,430,000$  soums

Total over three years:  $7,504,000 + 1,372,000 + 1,430,000 = 10,306,000$  soums.

Total costs for chemical treatment are 16,640,000 soums in the first year, 17,000,000 soums in the second year, and 17,400,000 soums in the third year.

Total:  $16,640,000 + 17,000,000 + 17,400,000 = 51,040,000$  soums.

Note: These calculations were prepared taking into account the average value of estimated changes in inflation rates for both methods over three years. The economic benefit is  $51,040,000 - 10,306,000 = 40,734,000$  soums.

Therefore, the electrotechnological treatment of apple trees in intensive orchards with UV-C rays against the pest aphid provides an economic benefit of 40,734,000 UZS compared to the traditional chemical method.

## GENERAL CONCLUSIONS

Based on the conducted research, the following conclusions are drawn:

1. Effective pest control in agriculture requires integrating agrotechnical measures with modern electrophysical methods, enabling pest elimination without chemical agents.
2. The use of UV-C radiation for controlling aphids in intensive apple orchards is feasible through the development and optimization of an electrotechnological device.
3. Due to the high energy of UV-C radiation and its natural absorption by the ozone layer, its effective artificial application depends on selecting optimal exposure parameters.
4. The interaction of electromagnetic radiation with plant tissues is determined by their electrical and dielectric properties, including resistance, permittivity, and dielectric losses.
5. High pest control efficiency is achieved when the device operates at close distances (0.3–0.6 m) with sufficient lamp power.
6. Optimal operating parameters were identified as a lamp power of 70 W, a distance of 0.3 m, and an exposure time of 20 minutes.
7. The proposed UV-C-based device provides significant economic benefits compared to chemical methods, ensuring cost savings of over 30 million UZS.

## REFERENCES

1. T.M. Bayzakov, Sh.B. Yusupov, I.J. Xolmirzayev “Инновационный метод борьбы с вредными насекомыми и болезнями растений с помощью ультрафиолетового света” Экономика и социум №3(118) 2024 [www.iupr.ru](http://www.iupr.ru).
2. Volkov A.G. *Plant Electrophysiology: Theory & Methodc.* – Springer, 2006. – P. 89–102.
3. T.M. Bayzakov, Sh.B. Yusupov, I.J. Xolmirzayev “O‘simlik zararkunandalariga ultrabinafsha nurlari bilan qarshi kurashish usullarini tadqiq etish”, “Фан ва технологиялар тараққиёти” Илмий-техникавий журнал №4/2024. 374-376-b.

---

4. Baykova O.L. *Ultraviolet irradiation and insect mortality*. – Novosibirsk: RAS Precc, 2012. – 198 c. – С. 117–122.

5. T.M. Bayzakov, Sh.B. Yusupov, I.J. Xolmirzayev, “O‘simliklarni zararli hasharotlardan himoya qilishning elektrofizik usulining samaradorligi” Scientific-technical journal (STJ FerPI, ФирПИ ИТЖ, ИТЖ ФерПИ, 2024, Т.28, №4)-P.243-245.

6. ГОСТ 53056-2008. Техника сельскохозяйственная. Метода экономической отценки.-М.: Изд-во стандартинофи, 2009.-19 с.