

Requirements for Transmission, Steering Gears Control And Suspension of the Carher for Hot Climate Conditions

Avlyyokulov J.S. PhD, Associate Professor,
Rakhmatov M. Senior Lecturer,
Tadzhiev R.D. Undergraduate
Tashkent State Transport University

Abstract: Preparation of transmission mechanisms of vehicles intended for operation in sandy-desert terrain provides for cleaning mechanisms from dust and dirt, checking the serviceability of all mechanisms and adjusting them in accordance with the instructions of manufacturers' instructions, cleaning external parts and crankcases of mechanisms from accumulations of contaminants and used oils and lubricants.

Particular attention should be paid to cleaning the spline joints of the cardan shafts and filling them with fresh lubricant.

Keywords: transmission mechanisms, vehicles

Preparation of transmission mechanisms of vehicles intended for operation in sandy-desert terrain provides for cleaning mechanisms from dust and dirt, checking the serviceability of all mechanisms and adjusting them in accordance with the instructions of manufacturers' instructions, cleaning external parts and crankcases of mechanisms from accumulations of contaminants and used oils and lubricants.

Particular attention should be paid to cleaning the spline joints of the cardan shafts and filling them with fresh lubricant.

It is recommended to turn out the press oilers of the transmission mechanisms, clean them of contaminants, check their serviceability and install them in place.

A feature of the preparation of the transmission mechanisms of cars for operation in these conditions is to check the correctness of the seals and clean the ventilation holes from contaminants.

Checking the serviceability of oil seals must be carried out after cleaning the mechanisms from dust and contaminants with the lubricant in them heated to 80 ° C. In this case, it is desirable that the crankcases of the gearbox, transfer case, drive axle and others would be filled with a washing mixture with a lower viscosity than the main lubricant. In this case, a mixture consisting of 75% industrial oil 12 or 20 (GOST 1707-91) and 25% kerosene can be recommended.

Heated when the car is moving, this mixture will not only help to detect a violation in the seals of the mechanisms, but also provide high-quality cleaning and washing of the internal cavity of the crankcases of the mechanisms from contamination. If there is a leakage of lubricant through the gland seals, it is necessary to tighten or replace them.

In case of detection of a lubricant leak or leaks, a special, sealing paste VTU MHP 3336-52 can be recommended as an additional seal of the crankcase connectors of the transmission mechanisms of cars, including hatch covers, the use of which in these conditions ensures the required tightness.

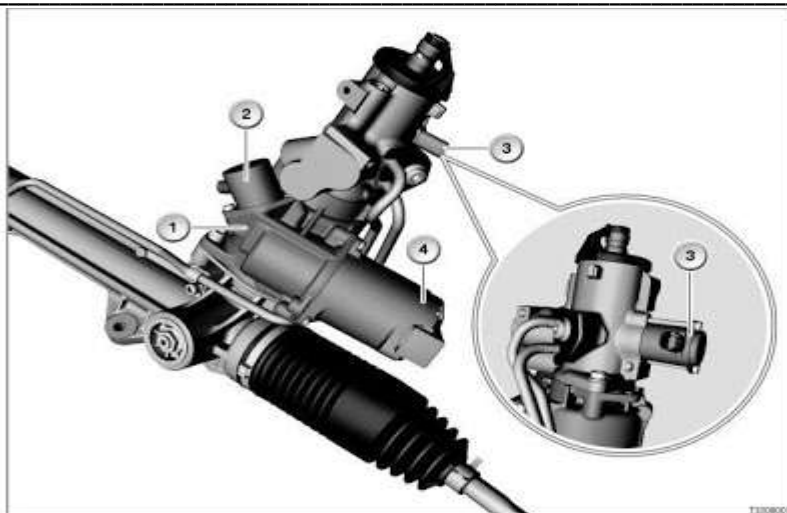

На рисунке изображен BMW X5

| Обозначение | Пояснение | Обозначение | Пояснение |
|-------------|----------------------------------|-------------|---|
| 1 | Механизм наложения угла поворота | 2 | Блокиратор серводвигателя |
| 3 | Клапан сервоэлектроника | 4 | Серводвигатель с датчиком положения двигателя |

For high-quality cleaning of the ventilation holes of the mechanisms from contaminants, it is recommended to turn or disassemble them, rinse in kerosene and blow with compressed air. Before installing the ventilation device in place, check and, if necessary, clean the ventilation ducts made in the crankcases of the mechanisms from contaminants.

When preparing the steering mechanism, it is cleaned of contaminants, the serviceability is checked and, if necessary, the parts are repaired. In case of significant contamination, as well as the presence of traces of corrosion on them, these parts or mechanisms must be removed from the car, washed in kerosene, checked their serviceability, and then reassembled. When driving on sandy soils, the steering of the car experiences an increased load.

At the same time, due to increased resistance to turning the wheels in the steering rods and their connections, additional loads arise, leading, as a rule, to an increase in the gaps in the hinged joints of the steering rods. With this in mind, it is necessary, when preparing the steering, to strictly maintain the clearances established for them in order to prevent their further increase during operation.

Most modern trucks have power steering to facilitate control. When preparing the power steering, it is necessary to clean it from contaminated oil, rinse with clean, filtered oil and clean double-mesh filters from contaminants.

In the event of significant contamination of filter nets with resinous deposits, they should be washed with solvent 646 used in the painting of automobiles.

High and low pressure hoses with traces of scuffs, delaminations, cracks and places of destruction should be replaced.

Particular attention shall be paid to the serviceability and proper tension of the drive belt of the power steering pump. With normal tension, the belt deflection between the pulleys of the fan and the hydraulic booster pump under the action of a load of about 4 N should be within 10-.15 mm

Upon completion of the inspection, troubleshooting and necessary adjustments, the power steering system shall be completely filled with clean, filtered oil of the appropriate summer grade.

When operating cars in sandy-desert terrain, especially when driving off-road, the suspension of the car experiences an increased load. When preparing the suspension of cars for operation in these conditions, it is necessary to clean the springs and shock absorbers from contaminants, check their serviceability, clean the spring sheets from traces of corrosion and lubricate with graphite lubricant USSA (GOST 3333-55). The fingers of the springs and ladders of the suspension are thoroughly cleaned of dirt, check the serviceability of the channels supplying the lubricant, and install the fingers of the springs in place.

For cars that have rubber cushions, check their serviceability, the absence of traces of increased deposits and destruction and rinse in warm water. Rubber spring cushions, which have increased wear and significant destruction, replace.

References:

1. Automobile transport of Uzbekistan 2004 - 2005 "Blue Book" Moscow.
2. "Transport of Tashkent" D.A. Sharakhmedov, S.G. Gulyamov. Tashkent 2006
3. Riskulov, A. A., Avliyokulov, J. S., & Rakhmatov, M. I. (2021). REALIZATION OF THE PHENOMENON OF NANOSTAGION OF INDUSTRIAL THERMOPLASTICS. *Bulletin of Science and Education*, (12-1 (115)), 38-40.
4. Avliyokulov, J. S., Narziev, S. O., & Magdiev, Sh. P. (2021). STUDY OF THE FREQUENCY OF ENGINE OIL CHANGE IN OPERATING CONDITIONS. *Bulletin of Science and Education*, (9-3 (112)), 16-19.
5. Magdiev, Sh. P., Avliekulov, Zh. S., & Narziev, S. O. ANALYSIS OF ENERGY-SAVING PROPERTIES OF MOTOR OILS IN OPERATING CONDITIONS. *ompozitsion*, 176.
6. Nurmetov, K., Riskulov, A., & Avliyokulov, J. (2021). Composite tribotechnical materials for autotractors assemblies. In *E3S Web of Conferences* (Vol. 264). EDP Sciences.