

Compensation of Technological Error During Thread Cutting

Urinov Nasullo Fayzullaevich - Candidate of technical sciences, associate professor
Zainiev Khudoyberdi Mukhiddinovich – Probationer teacher
Bukhara Engineering-Technological Institute

Annotation. The article covers one of the factors affecting the processing kinematic threads procedure and contributing to decrease in the error in the manufacture of threads - the size of the removed allowance. Generally, we will focus on allowance for the final processing, where all accuracy parameters must be complied.

Keywords: kinematic thread, thread pitch error, screw-grinding machine, technological error, helix lifting angle, reduced average diameter, tooth height, dimension chain.

I. Introduction.

The main requirements for the feed screws of the rolling pairs (kinematic threads) are ensuring the correct profile of the helical flute, the absence of microcracks, and accuracy of threads in the axial and radial sections.

Kinematic threads have guaranteed clearances on bearing surfaces. These clearances are necessary to disposition of lubricant and reduce friction, and to temperature deformations compensations. The main indicator of accuracy of the kinematic thread is the difference between the actual and theoretical shifts of one of the screw pair parts in the axial direction.

The main research work is directed at studying the causes of origination and ways of reducing the pitch error. Based on the analysis of these works, errors can be conditionally divided into two types (depending on the causes of origination): design, technological.

The most studied are structural errors, i.e. errors due to inaccuracies in the manufacture and assembly of parts and knots of screw-grinding machine: errors in the kinematic chains of movement of the machine table and rotation of the product spindle, axial and radial beat of the spindle, etc.

II. Methodology.

Technological errors include screw-based errors; temperature and elastic deformations of the technological system; errors caused by fluctuations in the properties of grinding disk and blanks, as well as errors caused by the machine setting and professional skills of the worker, errors in positioning the profile of the grinding disk in the axial and radial direction relative to the profile of the processed thread, errors caused by deviations of the grinding and trimming conditions of the grinding disk [2].

The greatest difficulties in practice cause errors due to axial temperature deformation of the blanks during thread grinding [3]. This is because a large number of factors of the processing affects the temperature deformation of the blanks in the axial direction: the cutting property of the grinding disk, the temperature of the lubricant-cooling agent and its thermal-physical properties, cooling time and length of the cooled section, cutting modes, dimension type and properties of the blank, the size of the removed allowance, the cyclicity of heating by the design of a multistrand thread grinding disk.

Let us consider one of the factors affecting the processing kinematic threads procedure and contributing to decrease in the error in the manufacture of threads - the size of the removed allowance. Generally, we will focus on allowance for the final processing, where all accuracy parameters must be complied.

Thread grinding is the most common method of kinematic thread finishing, and allows obtaining the seventh and lower degrees accuracy of the thread. Issues of achieving the required quality during thread grinding are currently relevant.

The following main types of thread grinding are used to form threads on the surface of parts:

- 1) External thread grinding on round parts,
- 2) Thread grinding of round parts on the inner surface,
- 3) Thread grinding on flat parts,
- 4) Tooth cutting in rails, etc.

Thread grinding process usually consists of two operations (preliminary and final grinding), and for extremely precise screws at the large thread pitch consists of three operations. It is very important to calculate the exact allowance for all operations.

The finishing of threads of the hardened lead screws is carried out on thread grinding machines. A single-profile grinding disk with abundant cooling performs preliminary and final grinding. The use of cutting coolant reduces friction and adhesion of the chips to the working surface of the grinding disk, which preserves its cutting properties, and helps to remove heat and the resulting chips, which directly affect the accuracy of the machined thread.

The use of disks from el'bor borazon material in operations of preliminary and final grinding of the radius and lancet arched profile of the thread of the screws can simultaneously improve labor productivity, accuracy and quality of grinding. As when grinding other thread profiles, it is necessary to maintain constant temperature in the room and warm up the machine before idling for at least 0.5-1 hours. This allows grinding the screws with an exact step, the tolerance of which does not exceed 2-3 microns. To exclude vibrations during grinding and traces of cutting the work surface, the grinding wheel should carefully be balanced with the faceplate, and be aligned to the profile corresponding to the grinding thread.

The choice of disk characteristics depends on the pitch, thread length and type of grinding. Fine threads are ground with 6-M28 granularity disks. These disks provide a less rough surface of the thread, but they have a lower cutting ability than large-grain disks, and under intense cutting conditions cause burns. Too hard circles are quickly greased, and too soft intensively deteriorated and do not provide the required precision for screws production.

III. Experimental results.

The main technological problems of controlling the accuracy of profile gear grinding are related to variable value of allowance on the tooth profile, which depends on the technologically inherited errors of the blank coming to the grinding operation. Another problem is the incorrect distribution of the stock of the blank, which reduces productivity and accuracy when gear grinding and further can lead to defect.

Let us calculate the minimum allowance for thread-grinding processing taking into account the allowance left after turning (roughing) operation, decarburized layer after thermal operation, profile angle errors and thread pitch.

The thread is based on a helical line. If we take a piece of paper in the form of a right-angled triangle ABC, in which the BC leg is equal to the circumference of the cylinder with a diameter D, that is, $BC = \pi D$, and the second AC leg is equal to the height of the helical line in one turn [1]. Twisting the triangle onto a cylindrical surface, the BC leg will wrap around the cylinder once, and the hypotenuse AB will twist onto the cylinder and form on its surface *the helical line with a pitch S* equal to AC. The angle φ is called the *lifting angle of the helical line*.

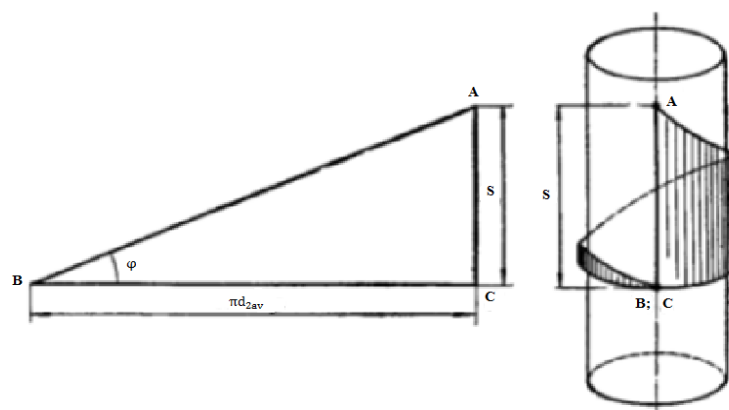

Fig 1. Formation of a helical surface

Calculation of the reduced thread diameter ($d_{\text{прив}}$), tooth cavity (S) and tolerance on it (TS).

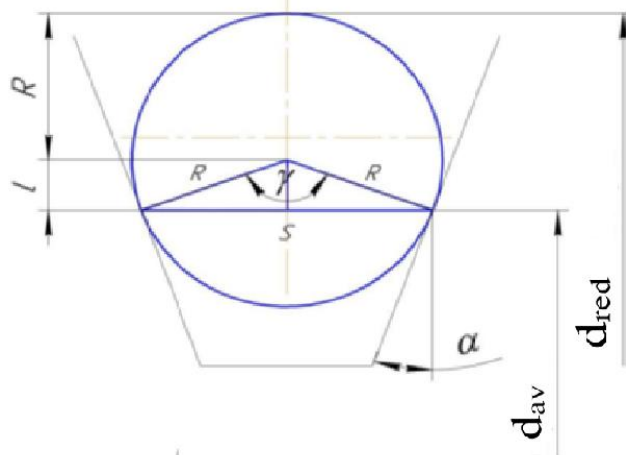

Fig. 2. Position of the measuring roller in the profile of teeth.

From Fig. 2 we will find the width of the cavity (chord S) on the given average diameter $d_{\text{прив}}$ (which will be calculated later):

$$S = 2R \cdot \sin\left(\frac{\gamma}{2}\right)$$

Tolerance on width of the cavity: $TS = \left(\frac{d_{(\max)} - d_{(\min)}}{2} \cdot \text{tg}20^\circ\right) \cdot 2$

To determine the reduced average diameter, we calculate the height of chord (L) from the right triangle in Fig. 1.

$$L = \sin \alpha \cdot R;$$

Reduced average diameter: $d_{\text{прив}} = d - 2(L + R).$

Calculation of the measuring height of the width of the tooth cavity: $m_{\text{mea}} = \frac{d_a - d_{\text{ред}}}{2}.$

Calculation of grinding allowance after turning and heat treatment.

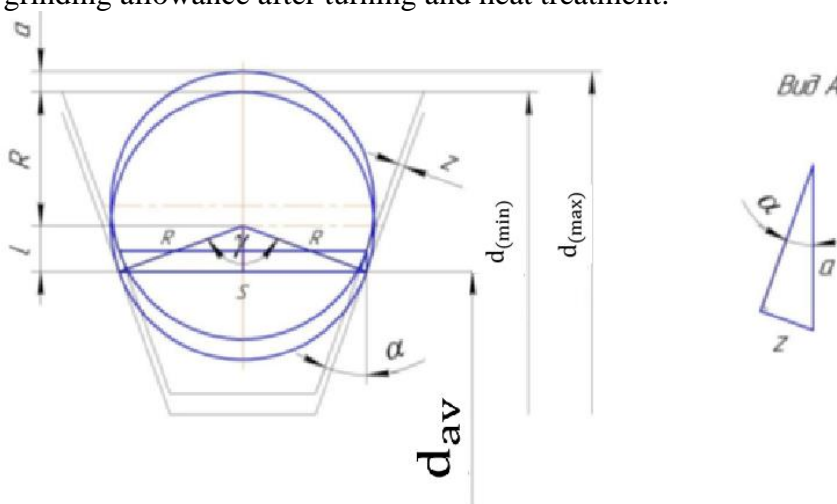

Fig.3 Determination of allowance.

From a right-angled triangle in view A, we find grinding allowances Z: $z = \sin \alpha \cdot a$, where $a = \left(\frac{d_{\text{ав}} - d}{2}\right);$

Determination of the allowance (z') for the grinding operation, taking into account the angle error ($\Delta\alpha$) and step error (ΔP).

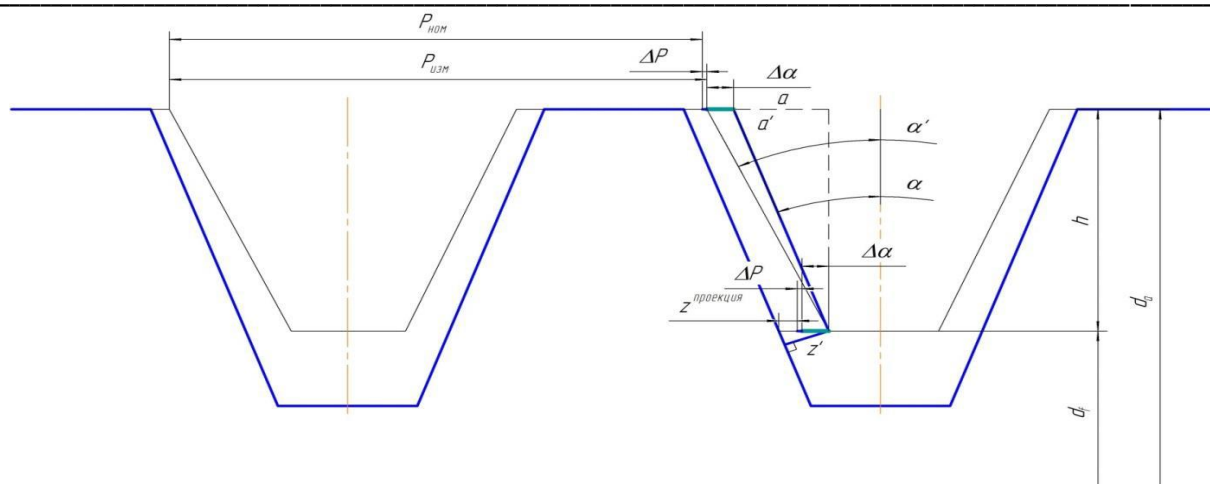

Fig. 4. Profile draft for building a dimensional chain.

Determine the height of the tooth before grinding:

$$h = \frac{d_a - d_f}{2};$$

Then calculate the angle and pitch error:

$$\Delta\alpha = a' - a = \text{tg } \alpha' \cdot h - \text{tg } \alpha \cdot h;$$

$$\Delta P = P_{\text{mea}} - P_{\text{nom}};$$

From the dimensional chain we find $z'^{\text{projection}}$:

$$z'^{\text{projection}} = z^{\text{projection}} + \Delta\alpha + \Delta P;$$

where $z^{\text{projection}} = z / \cos 20^\circ$.

Build a dimensional chain to find z' (Fig.5)

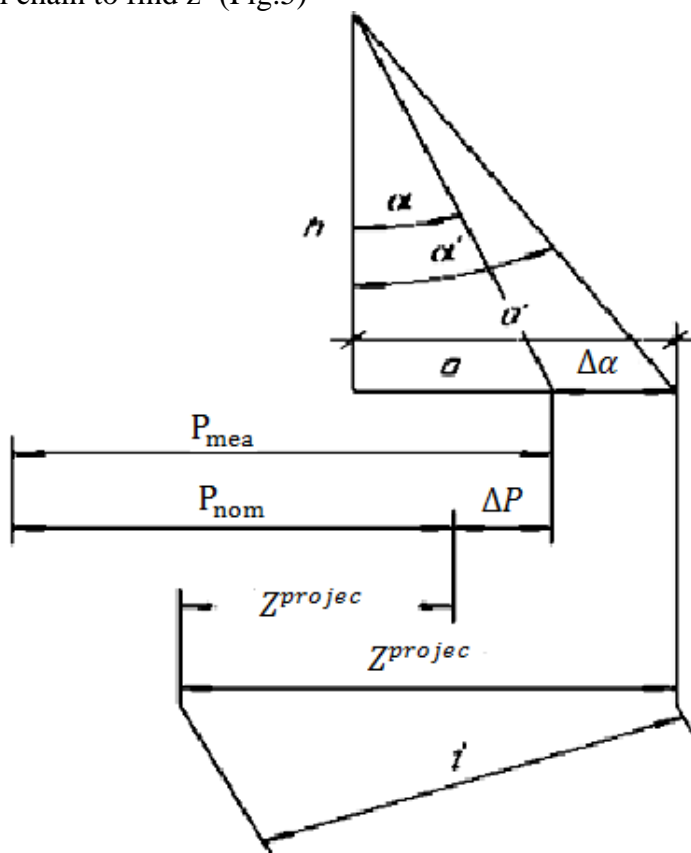

Fig. 5. Dimensional chain

Therefore, the allowance for the grinding operation will be:

$$z' = \cos 20^\circ \cdot z_{\text{projection}}$$

IV. Conclusions

Machining of the thread's screw surface is one of the most complex technological processes of the machining. Before performing thread grinding, it is necessary to make sure that the right allowance left after the turning operation. Because of the work, the existing options for achieving accuracy in thread grinding were evaluated. The most suitable and optimal thread grinding option was selected based on the features of the equipment and specified batch of shafts with threaded surface

References.

1. Gazizov A.F. Mechanical engineering and theoretical engineering, computer modeling of processing and grinding of external helical surfaces using the example of Archimedean worm screw // Contact information of the conference organizing committee. - 2017. - p. 25.
2. Sokolov V.F. Analysis of errors in the thread formation of lead screw // Інформаційні технології в освіті, науці та виробництві. – 2015. – No. 3 (8).
3. Tulpa S.M. Thread-grinding work. – Yuri Vishnevsky, 1973- pp. 5-23.